

por la precisión · passione per la precisione · a passion for precision · passion pour la précision · pasión por

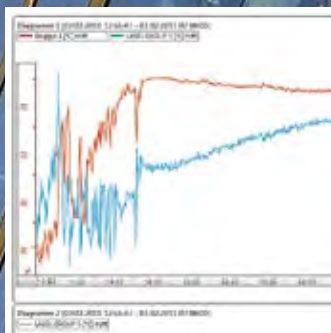

**Measure and record
data easily and
precisely.**

*Quality made in
Germany without
compromises.*

Precision in the

Palm of your Hand



The highly demanding and complex measuring tasks of today can only be mastered with high-precision devices. The special requirements placed on hand-held measuring devices are the result of the spectrum of physical measurements that are to be measured, as well as the decisions that are based on this measured data. Architects, specialists and surveyors, engineers, climate experts and many other professionals bear the responsibility for people, technology, goods and processes. Whether you are investigating or recording the temperature of a surface without contact, the dew point temperature of air on walls, the moisture content of oil, air pressure or air flow, Lufft hand-held devices are easy to operate and – above all – precise!

The **XA1000 hand-held-measuring device** is an all-round device that fulfils the highest demands. Various high-precision climatic measuring technology sensors can be alternatively connected. The measurement results are displayed in high resolution colour displays both in graphic and numeric formats. The integrated data recorder allows the measurement results to be transferred to a computer; for this purpose the Lufft software SmartGraph3 is ready and waiting.

The **XP Series** consists of hand-held measuring devices for specialists. The highest temperature precision combined with the most modern handling of measured data. This also applies to air-flow, temperature and relative humidity, as well as CO₂. The ideal hand-held measuring device for any measuring task. Available as of July 2013.

The **XC Series** rounds off the diverse range of hand-held measuring devices. A special option is the combination of temperature/relative humidity with (infrared) surface temperature in order to identify areas affected by dampness e.g. in the walls of buildings. Available as of October 2013.

The **OPUS20 Dataloggers** are the stationary equivalent of the X-Series hand-held measuring devices. Many of the sensors offered can be used with both X-Series and OPUS20 Dataloggers. The devices are available with built-in sensors as well as with external sensors (intelligent) that can be connected. The OPUS20 are LAN capable and are configured and analyzed using SmartGraph3.

The Software

SmartGraph3 manages and files measured data from both hand-held measuring devices and dataloggers. The managing of data can be carried out in real time (LAN datalogger) or also in cyclical readouts of the monitoring network. The configuration section of SmartGraph3 allows the measuring components to be setup for their respective applications. If the scope of operation of SmartGraph3 is not adequate for a special application, then we offer the optional **Software MCPST** which fulfils all customer requirements up to and including customer-specific solutions.

Brand of the Century

As the only measurement technology company in its segment, Lufft was presented with this special award in 2012 as recognition for its uncompromising quality within the temperature measurement technology during its 100 year company history.

Calibration rounds off the quality requirements. Measuring devices without a measuring log lack traceability. The reference measurement in conjunction with reference norms ensures that your measuring device remains your reliable supplier of measured

data throughout its entire period of use. Lufft is DKD-Labor certified for temperature, relative humidity, air pressure and airflow.

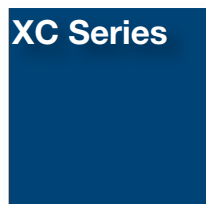
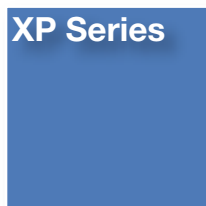
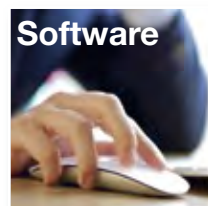
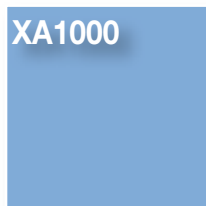

**As tasks increase
so do requirements.**

*Lufft's sophisticated
measuring technology
is more than a match for
today's high demands.*

Functions and

Measurement Categories



Lufft's hand-held measuring device product range is comprehensive and can be implemented in a full spectrum of various application areas. By using the table below you will be able to get an overview of the most important device features. This will enable you to find the right device from the various series that best meets your needs. Take your time and compare the range of functions offered with those of competitors' products and you will discover that Lufft is in a class of its own.

The physical measurements offered are the most important factor when selecting a hand held device for various applications. For this purpose we have compiled a concise table to be used as a general overview. More detailed information regarding our measuring devices and connectable sensors can be found in the technical descriptions on the following pages.

Functions				
Functions and Features of Lufft Measuring Devices				
Functions and Features	XA1000	XP100	XP200	XP400
Colour TFT-LCD (QVGA)	■	■	■	■
Legible in sunlight	■	■	■	■
Illumination dimmable	■	■	■	■
Touch operation	■	■	■	■
SmartGraph3 support (USB)	■	■	■	■
Firmware update possible online	■	■	■	■
Interface for SDI and digital sensors	■	■	■	■
Data storage (200 data files/1Mio measured values)	■	■	■	■
Low power design (>24h@4xAA)	■	■	■	■
Intuitive operation	■	■	■	■
Graphical user interface	■	■	■	■

Measurement Categories					
What you can measure with Lufft measuring devices - now and in the future.					
Measurement Categories		XA1000	XP100	XP200	XP400
Temperature (C° /°F)	Air temperature	■	■	■	■
	Surface temperature		■		
	Infrared temperature (non-contact)				
	Dew point temperature of the air	■			
	Dew point temperature on walls				
Humidity %r.h.	Air humidity	■		■	
	Absolute humidity	■		■	
Airflow (m³/s)	Airflow	■			■
Pressure (hPa)	Absolute pressure	■			
	Air pressure	■			
CO₂	CO ₂ concentration (ppm)				

The multi-talented device on the measuring technology scene.

One device instead of several – universal and flexible thanks to its digital sensor interface.

X(per) A(dvanced)

XAT1000

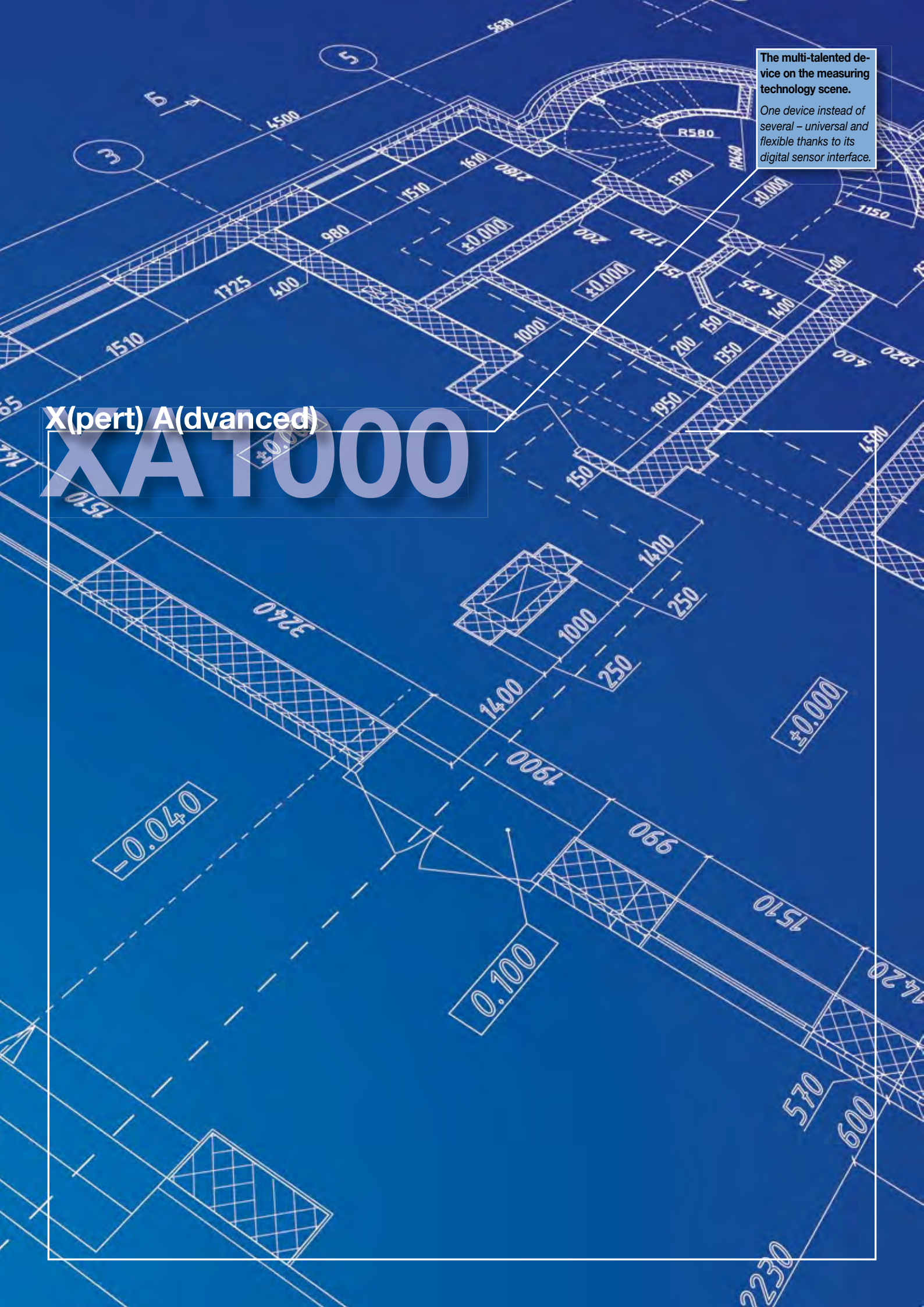



A complete package: the XA1000 is specially engineered for the requirements in the areas of heating/air conditioning and ventilation to measure temperature, humidity and air flow.

Without a doubt the XA Series represents the advanced technology in Lufft's measuring device product range – a specially advanced device generation that utilises luminous colour displays and works with intelligent sensors. With the help of SmartGraph3, the recorded data taken from your measuring campaigns can be archived and analysed clearly.

The Smartphone for measurement technology – this was the requirement for the product development of the XA1000.

The ergonomic-optimised hand-held measuring device automatically recognises each connected sensor. The colour display reacts to your touch; alternatively the control pad below the display can be used to control the functions. In addition to the high-resolution representation of the measured values, the measuring curves can also be analysed in chronological sequence on the display.

As a special feature, the XA1000 comes with all possible calculations that can be determined with the help of the measured physical measurements: Dew point, wet-bulb temperature, absolute humidity, enthalpy and much more.

The Windows compatible SmartGraph3 software is included in delivery and in addition provides a clear representation and simple compilation of all measured data. This full-featured software can display measured values in both tables and graphs and possesses standard functions such as print and export, as well as zoom and scroll tools for specific, graphical analysis.



Robust technology
in a sophisticated
design.

*Precision and reliability
in one – made by
professionals for
professionals*

Measuring on the Go

- TFT colour display, legible in sunlight
- Capacitive touch operation
- Sampling rate 1s
- Data recording of up to 3 channels in parallel
- Graphical analysis with standard deviation representation
- Integrated Flash memory for 200 recording blocks with maximum length of 3 hours
- USB port for data transfer to SmartGraph3 (included in delivery)
- Various languages selectable
- Measuring temperature, humidity, airflow via external digital sensors
- Integrated air pressure measurement
- Numerous calculated measurements
- Online firmware update

MADE IN GERMANY

Premium Segment XA1000



The best precision and greatest flexibility. The measurement all-rounder for professional applications – easy to handle and robust. Allows various intelligent sensors to be connected, sensors to be automatically recognised, saves measuring campaigns, allows all climate data to be calculated, and data to be archived on a computer and easily evaluated by means of SmartGraph3.

Hand-held Measuring Device XA1000 "All-in-ONE"		Order No.
"All-rounder" in the measurement technology segment. A universal measuring device for professionals with the inclusion of exchangeable SDI Sensors. Highly precise measurements of temperature and relative humidity. Integrated air pressure sensor, online/offline data recording. Equipment test certificate, can be calibrated.		5900.00
Technical data	Dimensions	170x62x34mm
	Weight	ca. 205g
Storage conditions	Permitted ambient temperature	-20...+60°C
	Permitted rel. humidity	<90%r.h. non-condensing
Operating conditions	Permitted rel. humidity	<90%r.h. (20g/m ³) non-condensing
	Permitted altitude above sea level	4,000m
Power supply	Power supply	4 Alkaline LR6 AA/NiMH 1.5...1.2V/USB 5V
	Active power consumption	Approx. 400mW
	Battery life passive	Approx. 1 year
	Battery life active	min. 24 hours
Data storage	Sensor power supply	5.5V ± 10% DC, max. 200mA
	Integrated data storage	up to 200 gauges taking approx. 1 mill. values
Interface	USB	Cable and SmartGraph3 software included in delivery
Representation	Definition of measured values	2 decimal places
Display	Control	Touch screen, capacitive
	Technology	TFT, resolution 240x320, 65k colours, very good contrast due to Piezoresistive technology
Integrated air pressure sensor	Surface, toughened glass	Degree of hardness: 7, scratch-resistant
	Measuring range (full accuracy)	800...1,100mbar
	Accuracy at 25°C, 1013,25mb	0.5mbar
	Long-term stability	type - 1mbar/year
	Measurement resolution	0.024mbar
Calculated measurement categories for external temperature/humidity sensors	Measuring principle	Piezoresistive
	Mathematical: MIN/MAX/AVG/HOLD	
	Temperature (°C/°F)	
	Rel. humidity (%r.h)	
	Rel. humidity of ice (%r.h)	
	Water vapour density (absolute humidity) g/m ³	
	Dew point temperature °C/°F	
	Frost point temperature °C/°F	
	Mixing ratio at saturation (100%) g/kg	
	Volume fraction of water vapour /mass fraction of water vapour (%)	
	Wet-bulb temperature °C/°F	
	Ice-bulb temperature °C/°F	
	Specific Enthalpy (mass of air) kJ/kg	
	Saturation vapour pressure above ice/water (hPa)	
	Vapour particle pressure (hPa)	
	Air density kg/m ³	
	Calculated measurement categories for external airflow sensors	Operating airflow volume - various units: (m ³ /s) (m ³ /h) (l/min)
Standard airflow volume: DIN 1343 (°C, 1013,25hPa), ISO 2533 (15°C, 1013,25hPa), DIN 1945 (20°C, 1013,25hPa)		
Various units: (m ³ /s), (m ³ /h), (l/min)		
Sensor/probe: all SDI/digital sensors (temperature, humidity, SDI airflow, air pressure integrated)		
Compatibility		

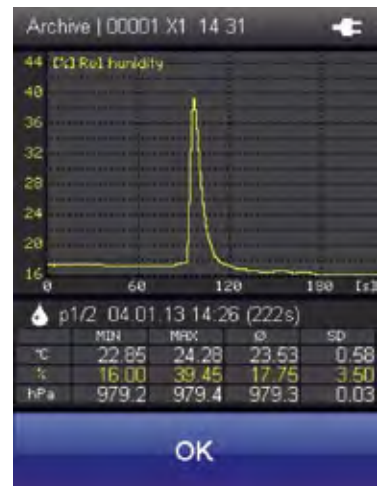

Compatible sensors for XA1000		Page
Temperature/humidity	digital TFF20	18
	Allround SDI	18
	4 mm diameter SDI	19
	High temperature SDI	19
	Sintered stainless steel filter	20
Current/temperature	SDI (0...2m/s)	21
	SDI (0...20m/s)	21

A high utility item combining elegant design with ease of use.

X(per) P(rofessional) Series

XP100

- TFT LCD , anti-glare colour display
- Capacitive touch screen
- Sampling rate 1s
- Data recording simultaneously on up to 3 channels
- Graphical analysis including standard deviation
- Integrated flash memory with space for up to 200 data blocks, or up to three hours continuous recording
- USB port for data transfer to Smartgraph 3 (included in delivery)
- Multilingual interface
- Numerous dimensions calculated
- Online firmware update



MADE IN GERMANY

Hand-held measuring device XP100 for measuring temperature



High-precision hand-held device for PT100 temperature sensors. Suitable for measuring tasks requiring a high degree of precision. Mini USB port with software and online data collection. 25 languages available, precise to 0.05C. Solely for use with PT100 sensors.

Hand-held device XP100		Order No.
Very exact temperature measuring device (+/-0.05C). Ideal as a reference device and for comparison measurements in service or as part of ISO9000 tasks. We recommend a DAkkS calibration certificate for traceability to international standards.		5810.00
Technical data	Dimensions	170x62x34 mm
	Weight	ca. 205g
Storage conditions	Permitted ambient temperature	-20...+60°C
	Permitted rel. humidity	<90%r.h. non-condensing
Operating conditions	Permitted rel. humidity	<90%r.h. (20g/m ³) non-condensing
	Permitted altitude above sea level	4,000m
Power supply	Power supply	4 Alkaline LR6 AA/NiMH 1.5...1.2V/USB 5V
	Active power consumption	Approx. 400mW
	Battery life passive	Approx. 1 year
	Battery life active	min. 24 hours
Data storage	Sensor power supply	5.5V ± 10% DC, max. 200mA
	Integrated data storage	up to 200 data/approx. 1 Mio measured values
Interface	USB	Cable and SmartGraph3 software included in delivery
Representation	Definition of measured values	2 decimal places
Display	Control	Touch screen, capacitive
	Technology	TFT, resolution 240x320, 65k colours, very good contrast due to Piezoresistive technology
	Surface, toughened glass	Degree of hardness: 7, scratch-resistant

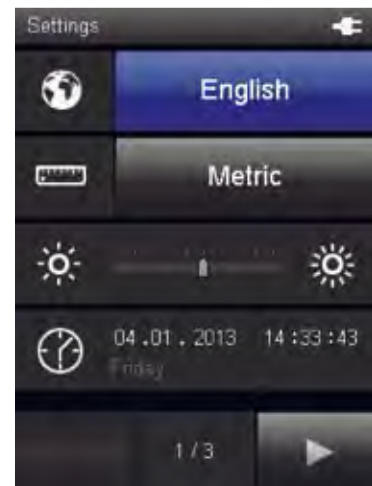
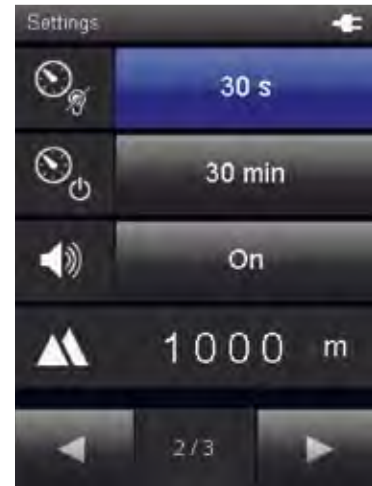

Compatible sensors for XP100		Page
Temperature	PT100 surface probe	17
	PT100 probe	16
	PT100 probe/ immersion probe (long)	16
	PT100 food probe, stainless steel	16
	Immersion probe 300x4mm	17

Genuine glass surface with high resolution colour display

X(per) P(rofessional) Series

XP200



- TFT LCD, anti-glare colour display
- Capacitive touch screen
- Sampling rate 1s
- Data recording simultaneously on up to 3 channels
- Graphical analysis including standard deviation
- Integrated flash memory with space for up to 200 data blocks, or up to three hours continuous recording
- USB port for data transfer to Smartgraph 3 (included in delivery)
- Multilingual interface
- Numerous dimensions calculated
- Online firmware update

MADE IN GERMANY

Hand-held measuring device XP200 for measuring temperature and humidity



X-perte range for humidity and temperature measurements in climate and environmental technology.

Hand-held measuring device XP200		Order No.
Temperature and humidity measuring device compatible with various intelligent sensors.		5820.00
Technical data	Dimensions	170x62x34 mm
	Weight	ca. 205g
Storage conditions	Permitted ambient temperature	-20...+60°C
	Permitted rel. humidity	<90%r.h. non-condensing
Operating conditions	Permitted rel. humidity	<90%r.h. (20g/m ³) non-condensing
	Permitted altitude above sea level	4,000m
Power supply	Power supply	4 Alkaline LR6 AA/NiMH 1.5...1.2V/USB 5V
	Active power consumption	Approx. 400mW
	Battery life passive	Approx. 1 year
	Battery life active	min. 24 hours
Data storage	Sensor power supply	5.5V ± 10% DC, max. 200mA
	Integrated data storage	up to 200 data/approx. 1 Mio measured values
Interface	USB	Cable and SmartGraph3 software included in delivery
Representation	Definition of measured values	2 decimal places
Display	Control	Touch screen, capacitive
	Technology	TFT, resolution 240x320, 65k colours, very good contrast due to Piezoresistive technology
Calculated measurement categories for external temperature/humidity sensors	Surface, toughened glass	Degree of hardness: 7, scratch-resistant
	Mathematical: MIN/MAX/AVG/HOLD	
	Temperature (°C/°F)	
	Rel. humidity (%r.h)	
	Rel. humidity of ice (%r.h)	
	Water vapour density (absolute humidity) g/m ³	
	Dew point temperature °C/°F	
	Frost point temperature °C/°F	
	Mixing ratio at saturation (100%) g/kg	
	Volume fraction of water vapour /mass fraction of water vapour (%)	
	Wet-bulb temperature °C/°F	
	Ice-bulb temperature °C/°F	
	Specific Enthalpy (mass of air) kJ/kg	
	Saturation vapour pressure above ice/water (hPa)	
	Water vapour particle pressure (hPa)	
Air density kg/m ³		

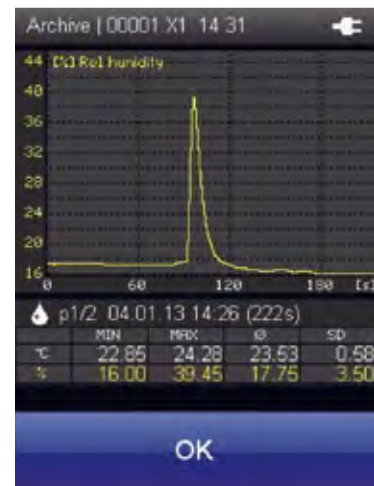

Compatible sensors for XP200		Page
Temperature/humidity	digital TFF20	18
	Allround SDI	18
	4 mm diameter SDI	19
	High temperature SDI	19
	Sintered stainless steel filter	20

Current measurements with time chart on a high resolution display

X(per) P(rofessional) Series

XP400

- TFT LCD, anti-glare colour display
- Capacitive touch screen
- Sampling rate 1s
- Data recording simultaneously on up to 3 channels
- Graphical analysis including standard deviation
- Integrated flash memory with space for up to 200 data blocks, or up to three hours continuous recording
- USB port for data transfer to Smartgraph 3 (included in delivery)
- Multilingual interface
- Current measurement via external, digital sensors
- Integrated atmospheric pressure measurement ability
- Numerous dimensions calculated
- Online firmware update



Hand-held measuring device XP400 for measuring current



Ideal for volume measurements, air intake and air discharge measurements in climate measuring technology. Data memory and software.

Hand-held measuring device XP400			Order No.
The X-pert for precise current measurements on various measurement ranges.			5840.00
Technical data	Dimensions	170x62x34 mm	
	Weight	ca. 205g	
Storage conditions	Permitted ambient temperature	-20...+60°C	
	Permitted rel. humidity	<90%r.h. non-condensing	
Operating conditions	Permitted rel. humidity	<90%r.h. (20g/m ³) non-condensing	
	Permitted altitude above sea level	4,000m	
	Power supply	4 Alkaline LR6 AA/NiMH 1.5...1.2V/USB 5V	
Power supply	Active power consumption	Approx. 400mW	
	Battery life passive	Approx. 1 year	
	Battery life active	min. 24 hours	
	Sensor power supply	5.5V ± 10% DC, max. 200mA	
Data storage	Integrated data storage	up to 200 data/approx. 1 Mio measured values	
Interface	USB	Cable and SmartGraph3 software included in delivery	
Representation	Definition of measured values	2 decimal places	
Display	Control	Touch screen, capacitive	
	Technology	TFT, resolution 240x320, 65k colours, very good contrast due to Piezoresistive technology	
	Surface, toughened glass	Degree of hardness: 7, scratch-resistant	
Calculated measurement categories for external airflow sensors	Operating airflow volume - various units: (m ³ /s) (m ³ /h) (l/min)		
	Standard airflow volume: DIN 1343 (°C, 1013,25hPa), ISO 2533 (15°C, 1013,25hPa), DIN 1945 (20°C, 1013,25hPa)		
	Various units: (m ³ /s), (m ³ /h), (l/min)		

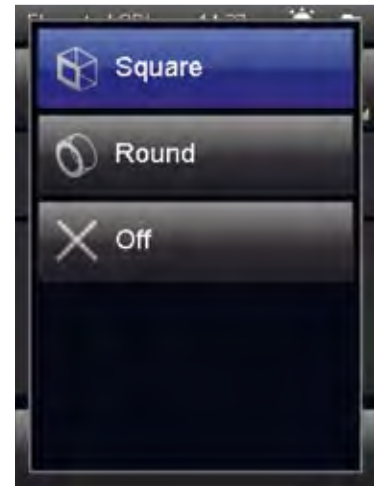

Compatible sensors for XP400		Page
Current/	SDI (0...2m/s)	21
Temperature	SDI (0...20m/s)	21

PT100 immersion probe

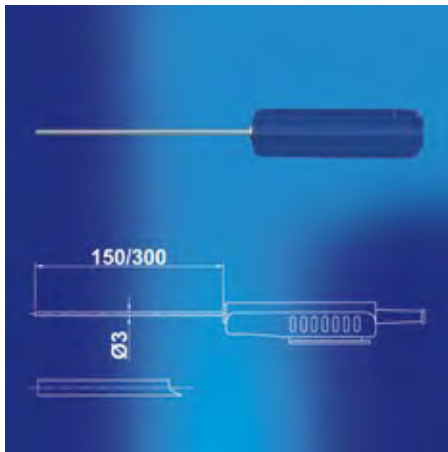

PT100 immersion probe			Order No.
The immersion probe is suitable for measurements in gaseous media, liquids and granular material, such as sand.			
Technical data	Dimensions, probe, short	150x3 mm	3120.520
	Dimensions, probe, long	300x3 mm	3120.530
Temperature	Dimensions, housing	119x27/35 mm	
	Weight	100g/120g	
	Protective housing	IP40	
	Max. permitted operating temperature	PUR cable and handle can be used up to 80°C	
	Storage temperature	-40 °C...+60 °C	
	Measurement range	-40 ... 400 °C	
	Accuracy	±0.15 + 0.002 x t	
Compatibility	Measuring technique	four terminal sensing	
	Reaction time	10 s	
	Cable length	approx. 1m	
Compatibility			XP100

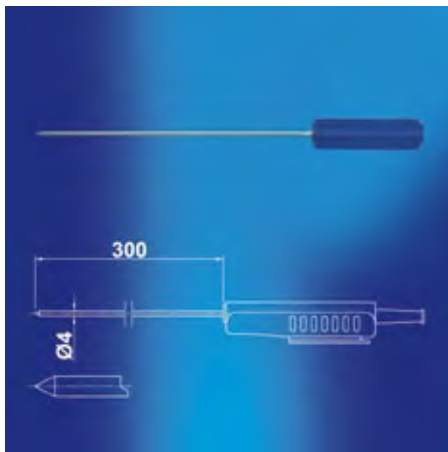

PT100 (immersion) probe, long			Order No.
This high-precision immersion probe in stainless steel protective housing can also be used as a reference sensor for calibration and testing systems.			3120.540
Technical data	Dimensions, probe	300x4 mm	
	Dimensions, housing	119x27/35 mm	
	Weight	120g	
	Protective housing	IP40	
	Max. permitted operating temperature	PUR cable and handle can be used up to 80°C	
Temperature	Measurement range	-40 ... 400 °C	
	Accuracy	±0.03 + 0.005 x t	
	Measuring technique	four terminal sensing	
	Reaction time	10 s	
Compatibility	Cable length	approx. 1m	
	Compatibility		

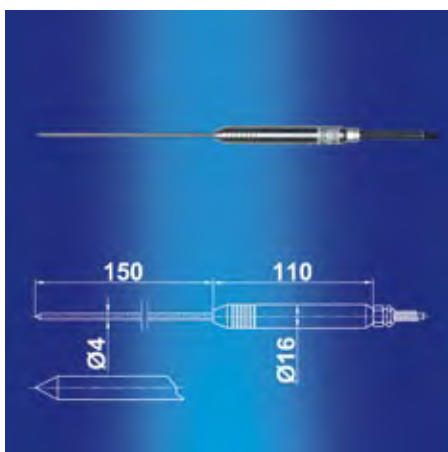

PT100 stainless steel food probe			Order No.
Food probe in stainless steel protective casing for precise temperature measurements			3120.550
Technical data	Dimensions, probe	150x4 mm	
	Dimensions, housing	110x16 mm	
	Weight	220g	
	Protective housing	IP65	
	Max. permitted operating temperature	PUR cable and handle can be used up to 80°C	
	Lagertemperatur	-40 °C...400 °C	
Temperature	Measurement range	-40 ... 400 °C	
	Accuracy	±0.03 + 0.005 x t	
	Measuring technique	four terminal sensing	
	Reaction time	10 s	
Compatibility	Cable length	approx. 1m	
	Compatibility		

PT100 Oberflächenfühler



PT100 surface probe		Order No.
At the head of the surface temperature probe is a spring-loaded sensor which takes the temperature. Can be used on flat, matt and metallic surfaces		3120.600
Technical data	Dimensions, probe	150x4,5mm
	Dimensions, housing	119x27/35mm
	Weight	120g
	Protective housing	IP30
	Max. permitted operating temperature	PUR cable and handle can be used up to 80°C
Temperature	Measurement range	-50 ... 400 °C
	Accuracy	±0.3 + 0.005 x t
	Reaction time t90	approx. 30s
	Measuring technique	four terminal sensing
	Cable length	approx. 1m
Compatibility	XP100	

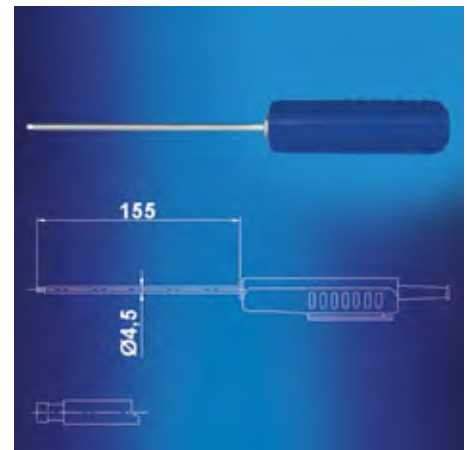

Immersion probe for XP100		Order No.
Accuracy with PT100 1/10 DIN 8 (0.05C) in stainless steel protective casing, mineralized sleeve.		3120.560
Technical data	Dimensions, probe	150x4 mm
	Dimensions, housing	119x27/35mm
	Weight	120g
	Protective housing	IP40
	Max. permitted operating temperature	PUR cable and handle can be used up to 80°C
	Storage temperature	-40 ... +60 °C
Temperature	Measurement range	-40 ... +400 °C
	Accuracy	0.05 °C at 0 °C
	Reaction time	10s
	Measuring technique	four terminal sensing
	Cable length	approx. 1m
Compatibility	XP100	

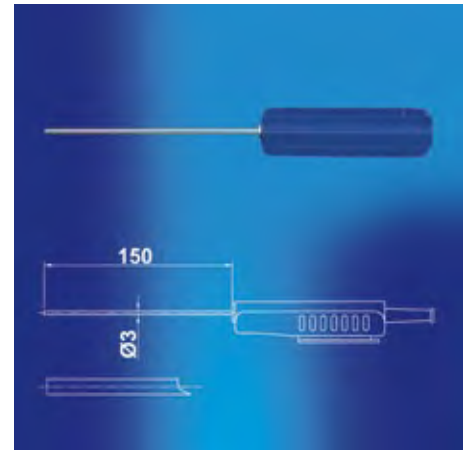



Temperature/Humidity Sensor



Digital TFF20			Order No.
<i>Reference measurement in service and maintenance, suitable for measurements in air conditioning and heating industry segments.</i>			5900.TFF
Technical Data	Dimensions	Length 85 mm, Ø 12 mm	
	Weight	Approx. 50g	
	Protection	Polycarbonate / IP65	
	Permitted operation temp.	0...50°C	
	Permitted humidity	0...95% r.h.	
	Storage temperature	-20...+60°C	
	Storage humidity	20...80% r.h.	
Relative Humidity	Measurement range	0.00 ... 100.00 % r.h.	
	Accuracy	±2 % (0 ... 90%), ±3 % (90 ... 100%) r.h.	
	Resolution	0.01% r.h.	
	Principle	capacitive	
Temperature	Measurement range	-40 ... 80 °C	
	Accuracy (20°C)	±0.1 °C	
	Accuracy (0...40°C)	±0.2 °C otherwise ±0.5 °C	
	Resolution	better 0.01 °C	
	Principle	PT1000, Class A, DIN EN 60751	
Absolute Humidity	Measurement range	0...300g/m ³	
	Unit	g/m ³	
Dew Point Temperature	Measurement range	-40...80°C	
Mixing Ratio	Measurement range	0...550g/kg	
Compatibility	XA1000		
Accessories	Stainless steel sinter cap		

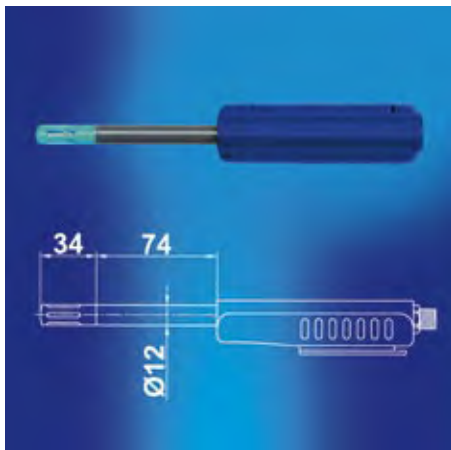

Allround SDI Temperature/Humidity Sensor			Order No.
<i>Compact temperature-/humidity sensor, in stainless steel tube. Application in HVAC field, reference measurement in accordance with ISO9000 Quality Assurance</i>			9130.540
Technical Data	Dimensions Sensor	Length 74 mm, Ø 12 mm	
	Dimensions Housing	117 x 38 mm	
	Weight	Approx. 80g	
	Protection	Housing/Sensor IP40 Sensor head plastic mesh	
	Permitted operation temp.	0...50°C	
	Permitted humidity	0...95% r.h.	
	Storage temperature	-20...60 °C	
Storage humidity	20...80% r.h.		
Relative Humidity	Measurement range	0 ... 100 % r.h.	
	Accuracy	±2 % (0 ... 90%), ±3 % (90 ... 100%) r.h.	
	Resolution	0.1% r.h.	
	Principle	capacitive	
Temperature	Measurement range	-20 ... 70 °C	
	Accuracy (20°C)	±0.2 °C	
	Accuracy (-10...50°C)	±0.4 °C otherwise ±0.5 °C	
	Resolution	0.1°C	
	Principle	NTC	
Compatibility	XA1000		
Accessories	Stainless steel sinter cap		

Temperature/Humidity Sensor



SDI Temperature-/Humidity Sensor with 4mm Diameter			Order No.
Compact, slim temperature-/humidity sensor in stainless steel protective tube. With a diameter of only 4mm, the sensor is suitable for applications in measurement areas that are difficult to access.			9130.520
Technical Data	Dimensions sensor tube	Length 250mm, Ø 4mm	
	Dimensions housing	117 x 38 mm	
	Weight	Approx. 85g	
	Protection	Housing IP40 / sensor IP40 sensor head: screwable, stainless steel cap, PTFE filter	
	Permitted operation temp.	0...50°C	
	Permitted humidity	0...95% r.h.	
	Storage temperature	-20...+60°C	
	Storage humidity	20...80% r.h.	
	Relative Humidity	Measurement range	0.00 ... 100.00 % r.F.
Accuracy		±2 % (0 ... 90 %), ±3 % (90 ... 100 %) r.h.	
Resolution		0.1% r.h.	
Principle		capacitive	
Temperature	Measurement range	-40 ... 100 °C	
	Accuracy	±0.2°C at 20 °C otherwise ±0.7°C	
	Resolution	0.1°C	
	Principle	PT1000 (tolerance class B, DIN EN 60751)	
Compatibility	XA1000		

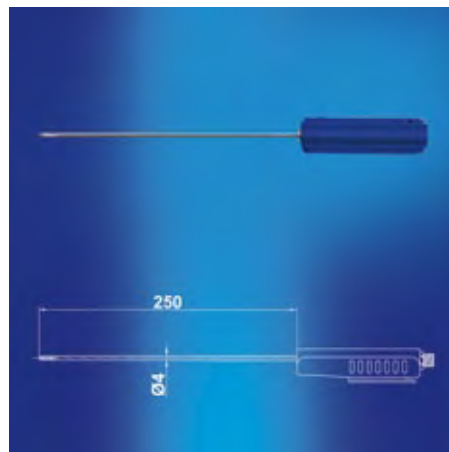

SDI High Temperature/Humidity Sensor			Order No.
Stainless steel sensor equipped with a Teflon probe is especially suitable for high temperature/humidity measurements.			9130.530
Technical Data	Dimensions sensor tube	Length 250mm, Ø 12mm	
	Dimensions housing	117 x 38 mm	
	Weight	Approx. 200g	
	Protection	Housing IP40 / sensor IP40 sensor head: stainless steel sinter filter	
	Permitted operation temp.	0...50°C	
	Permitted humidity	0...95% r.h.	
	Storage temperature	-20...+60°C	
	Storage humidity	20...80% r.h.	
	Relative Humidity	Measurement range	0.00 ... 100.00 % r.h.
Accuracy		±2 % (0 ... 90 %), ±3 % (90 ... 100 %) r.h.	
Resolution		0.1% r.h.	
Principle		capacitive	
Temperature	Measurement range	-40 ... 180 °C	
	Accuracy	±0.2°C at 20 °C otherwise ±0.7°C	
	Resolution	0.1°C	
	Principle	PT1000 (tolerance class B, DIN EN 60751)	
Compatibility	XA1000		

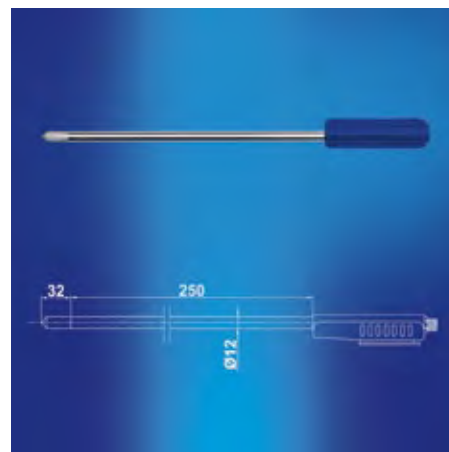



Temperature/Humidity Sensor



Stainless Steel Sinter Filter		Order No.
Stainless steel sinter filter for high dirt protection		5120.212
Technical data	Material	Sintered stainless steel
	Response time	30s
	Size of pores	10µm

SDI Airflow-/Temperature Sensor (0...2m/s)



SDI Airflow-/Temperature Sensor (0...2m/s)		Order No.
Reference device for airflow and temperature measurements in service and maintenance. Proof of air tightness of buildings and rooms.		6120.510
Technical data	Dimensions sensor tube	Length 200mm, Ø 6mm
	Dimensions housing	117 x 38mm
	Weight	Approx. 200g
	Protection	Housing: plastic (ABS) IP40 sensor head: stainless steel
	Permitted operation temp.	0...50°C
	Permitted humidity	0...95% r.h.
	Storage temperature	-20...+60°C
	Storage humidity	20...80% r.h.
Airflow	Measurement range	0...2m/s
	Accuracy	20°C, 45% r.h., 1013 hPa: ±(0.04m/s + 1% of measured value)
	Resolution	0.01 m/s
	Principle	Hot film anemometer
Temperature	Measurement range	-20...+70°C
	Accuracy	±0.7°C in the range 0...+50°C and v > 0.5m/s
	Resolution	0.1°C
	Principle	NTC
Compatibility	XA1000	

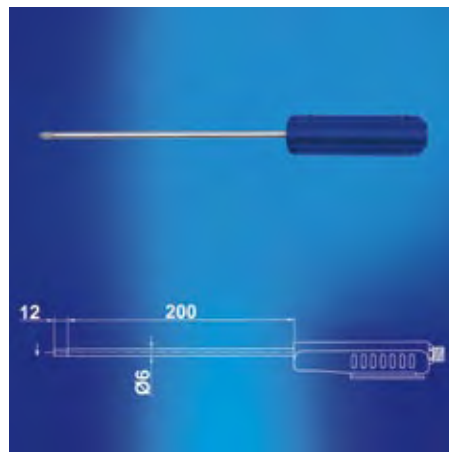

SDI Airflow-/Temperature Sensor (0...20m/s)		Order No.
Application: airflow and temperature measurements in climate measurement technology		6120.520
Technical data	Dimensions sensor tube	Length 200mm, Ø 6mm
	Dimensions housing	117 x 38mm
	Weight	Approx. 200g
	Protection	Housing: plastic (ABS) IP40 sensor head: stainless steel
	Permitted operation temp.	0...50°C
	Permitted humidity	0...95% r.h.
	Storage temperature	-20...+60°C
	Storage humidity	20...80% r.h.
Airflow	Measurement range	0...2m/s
	Accuracy	20°C, 45% r.h., 1013 hPa: ±(0.02m/s + 2% of measured value)
	Resolution	0.01 m/s
	Principle	Hot film anemometer
Temperature	Measurement range	-20...+70°C
	Accuracy	±0.7°C in the range 0...+50°C and v > 0.5m/s
	Resolution	0.1°C
	Principle	NTC
Compatibility	XA1000	

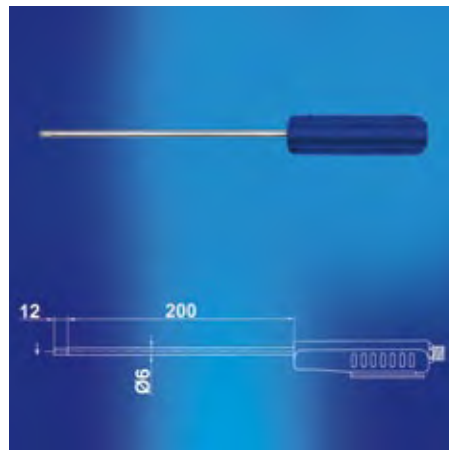

The world's toughest legal guidelines: 21 CFR Part 11 (electronic records).
The pharmaceutical industry trusts in Lufft.

Eliminate Fatal Consequences

OPUS20 Datalogger: threshold values always under control

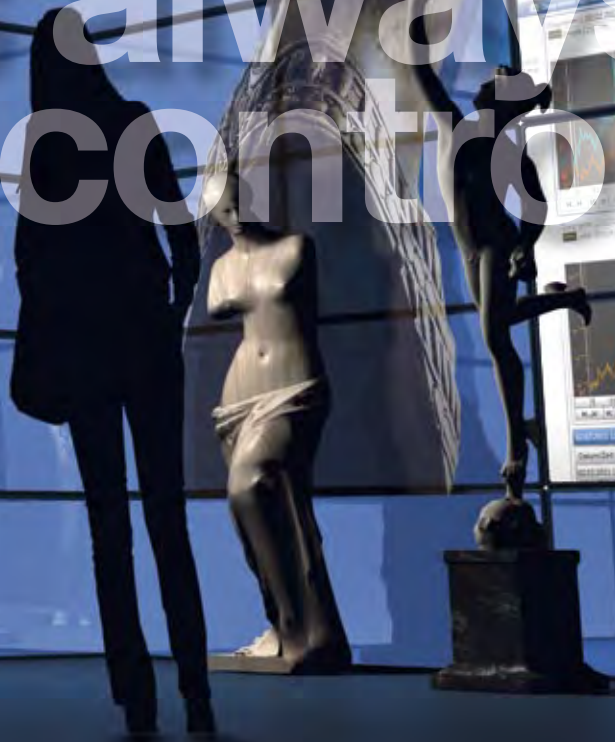
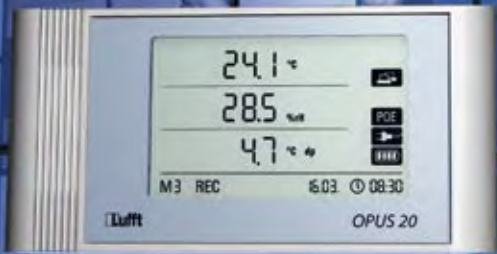

Lufft OPUS20 Functions



Functions	THI 8120.00	THIP 8120.10	TCO 8120.20	Lufft OPUS20 E 8120.30
Power supply battery	■	■	■	■
Power supply USB	■	■	■	■
Power supply LAN (POE)	optional	optional	optional	optional
Measured data storage	3,200,000	3,200,000	3,200,000	3,200,000
Typical battery life	> 1 year	> 1 year	> 4 months	> 4 months
LC-display	■	■	■	■
One-button operation	■	■	■	■
1-point calibration by user/operator	■	■	■	■
°C/°F switchable	■	■	■	■
Optical/acoustical alarm	■	■	■	■
Date/time	■	■	■	■
Records Min/Max/Avg.	■	■	■	■
SmartGraph 3 evaluation software	■	■	■	■
Measurement Categories	THI 8120.00	THIP 8120.10	TCO 8120.20	Lufft OPUS20 E 8120.30
Temperature				
Air temperature	■	■	■	■*
PT100				■**
Thermocouple				■**
Humidity				
Relative humidity	■	■	■	■*
Absolute humidity	■	■	■	■*
Dew point temperature	■	■	■	■*
Mixture ratio				■*
Air pressure				
Barometric air pressure		■		■*
Relative air pressure		■		■*
CO₂ Concentration				
CO ₂ Concentration			■	
External BUS-enabled digital sensor				
TFF20				■
External analog input				
Sensor input voltage				■***
Sensor input electric current				■***
Function Table Software	THI 8120.00	THIP 8120.10	TCO 8120.20	Lufft OPUS20 E 8120.30
Graphical representation	■	■	■	■
Numerical data (measured value display)	■	■	■	■
Print function	■	■	■	■
Export function for measured values (e.g. Excel)	■	■	■	■
Gathered printouts of all measurement sites	■	■	■	■
Administration of up to 255 measuring devices	■	■	■	■

* via external BUS-enabled sensor, optionally, max. 4 sensors with one OPUS20E

** via external analog sensors, optionally, 2 separate analog inputs

*** near analog/digital conversion of 0...1V, 0/4 ... 20 ma possible

THI



THIP



TCO



Lufft OPUS20 E





Lufft OPUS20 THI

Temperature and rel. Humidity

For climate monitoring in buildings and the control of all climate-sensitive production processes, in electronic data-processing centres, control cabinets, wind turbines, storage rooms and museums.

The OPUS20 runs on batteries or can be powered via USB. Alternatively, you have the possibility to power the device via POE (Power over Ethernet).

Lufft OPUS20 Temperature and Relative Humidity			Order-No.
Lufft OPUS20 Temperature / rel. Humidity (neutral without Lufft-Logo 8120.00N)			8120.00
Lufft OPUS20 Temperature / rel. Humidity PoE (neutral without Lufft-Logo 8120.01N)			8120.01
Technical data	Dimensions	length 166 mm, width 78 mm, depth 32 mm	
	Measurement rate	10/30s, 1/10/12/15/30min, 1/3/6/12/24h	
	Storage rate	1/10/12/15/30min, 1/3/6/12/24h	
	Construction	plastic housing	
	Operation life (battery)	> 1 Year	
	Data storage	16 MB, 3,200,000 measured values	
	LC-Display	size 90x64 mm	
	Weight	approx. 250g	
	Included in delivery	PC-Windows Software SmartGraph 3 for graphical and numerical representation of measured values / instruction manual / data cable / battery / DIN rail bracket	
	Interface	USB, LAN	
	Power supply	4 x LR6 AA Mignon, USB, (POE opt.)	
	Max. operation temperature	-20...50°C	
	Max. rel. humidity	0...95%r.h.<20g/m ³ (non condensing)	
	Max. altitude	10,000 m above sea level	
Temperature	Principle	NTC	
	Measurement range	-20... 50 °C	
	Accuracy	±0.3°C (0...40°C), otherwise 0.5°C	
	Resolution	0.1°C	
Rel. humidity	Principle	capacitive	
	Measurement range	0...100%r.h.	
	Accuracy	±2%r.h.,	
	Resolution	0.1%r.h.	
Accessories	4 x LR6 AA Mignon		8120.SV1
	Power supply adapter		8120.NT



The only LAN datalogger with built-in sensors and the highest precision

Lufft OPUS20 THIP Temperature, Rel. Humidity, Air Pressure



Lufft OPUS20 THIP Temperature, Relative Humidity, Air Pressure		Order-No.
Lufft OPUS20 THIP Temperature / Rel. Humidity / Air Pressure (neutral without Lufft-Logo 8120.10N)		8120.10
Lufft OPUS20 THIP Temperature / Rel. Humidity / Air Pressure PoE (neutral without Lufft-Logo 8120.11N)		8120.11
Technical data	Dimensions	length 166 mm, width 78 mm, depth 32 mm
	Measurement rate	10/30s, 1/10/12/15/30min, 1/3/6/12/24h
	Storage rate	1/10/12/15/30min, 1/3/6/12/24h
	Construction	plastic housing
	Operation life (battery)	> 1 Year
	Data storage	16 MB, 3,200,000 measured values
	LC-Display	size 90x64 mm
	Weight	approx. 250g
	Included in delivery	PC-Windows Software SmartGraph 3 for graphical and numerical representation of measured values / instruction manual/ data cable / battery / DIN rail bracket
	Interface	USB, LAN
	Power supply	4 x LR6 AA Mignon, USB, (POE opt.)
	Max. operation temperature	-20...50°C
	Max. rel. humidity	0...95%r.h.<20g/m ³ (non condensing)
	Max. altitude	10,000 m above sea level
Temperature	Principle	NTC
	Measurement range	-20 ... 50 °C
	Accuracy	±0.3°C (0...40°C), otherwise 0.5°C
	Resolution	0.1°C
Rel. humidity	Principle	capacitive
	Measurement range	0...100%r.h.
	Accuracy	±2%r.h.,
	Resolution	0.1%r.h.,
Air pressure	Measurement range	300 ... 1,300 hPa abs.
	Accuracy	700 ... 1,100mbar at 25°C ±0.5 hPa
	Resolution	0.1 hPa
Accessories	4 x LR6 AA Mignon	8120.SV1
	Power supply adapter	8120.NT

Finally available: Lufft's precise weather station for interior applications – an essential data collector for all calibration laboratories.





Lufft OPUS20 TCO

Temperature, Rel. Humidity, CO₂

The amount of carbon dioxide has been virtually constant at 280 ppm (parts per million) – i.e 280 gas molecules per million air molecules – the last ten thousand years. However in recent years, this measured value has been increasing rapidly at approx. 2 % per year.

A high level of CO₂ in the air within a room causes headaches, tiredness and lack of concentration. The regulation on CO₂ concentration was established in order to evaluate IAQ (Indoor Air Quality). Normal atmospheric air in so-called ‘clean air areas’ has a level of 360 ppm and approx. 500 ppm in urban areas. The limit of 1,000 ppm (“Pettenkofer Figure”) is still seen as being adequate indoor-air quality, which is especially important when regarding all meetings and conference rooms, as well as schools and open-plan offices.

As a guideline for school rooms in the USA the limit of 1,000 ppm applies; for workplaces the occupational exposure limit is 5,000 ppm.

Lufft OPUS20 TCO / Temperature / Relative Humidity / CO ₂			Order-No.
Lufft OPUS20 TCO / Temperature / Rel. Humidity / CO ₂ (neutral without Lufft-Logo 8120.20N)			8120.20
Lufft OPUS20 TCO / Temperature / Rel. Humidity / CO ₂ POE (neutral without Lufft-Logo 8120.21N)			8120.21
Technical data	Dimensions	length 166 mm, width 78 mm, depth 32mm	
	Measurement rate	10/30s, 1/10/12/15/30min, 1/3/6/12/24h	
	Storage rate	1/10/30min, 1/3/6/12/24h	
	Construction	plastic housing	
	Operation life (battery)	> 4 month	
	Data storage	16 MB, 3,200,000 measured values	
	LC-Display	size 90x64 mm	
	Weight	approx. 250g	
	Included in delivery	PC-Windows Software SmartGraph3 for graphical and numerical representation of measured values / instruction manual/ data cable / battery	
	Interface	USB, LAN	
	Power supply	4 x LR6 AA Mignon, USB, (POE opt.)	
	Max. operation temperature	-20...50°C	
	Max. rel. humidity	0...95%r.F.<20g/m ³ (non condensing)	
	Max. altitude	10,000 m above sea level	
Temperature	Principle	NTC	
	Measurement range	-20 ... 50 °C	
	Accuracy	±0.3°C (0...40°C), otherwise 0.5°C	
	Resolution	0.1°C	
Rel. Humidity	Principle	capacitive	
	Measurement range	0...100%r.h.	
	Accuracy	±2%r.h.,	
	Resolution	0.1%r.h.,	
CO₂	Principle	NDIR	
	Measurement range	0 ... 5,000 ppm	
	Accuracy	± 50 ppm +3% of measured value (at 20 ° C and 1,013 mbar)	
	Resolution	1 ppm	
	Long-term stability	20 ppm/a	
Accessories	4 x LR6 AA Mignon		8120.SV1
	Power supply adapter		8120.NT



Lufft OPUS20E for External Sensors



Lufft OPUS20E for External Sensors		Order-No.
Lufft OPUS20E (neutral without Lufft-Logo 8120.30N)		8120.30
Lufft OPUS20E PoE (neutral without Lufft-Logo 8120.31N)		8120.31
Technical data	Dimensions	length 180mm, width 78mm, depth 32mm
	Measurement rate	10/30s, 1/10/12/15/30min, 1/3/6/12/24h
	Storage rate	1/10/12/15/30min, 1/3/6/12/24h
	Construction	plastic housing
	Operation life (battery)	> 1 Year
	Data storage	16 MB, 3,200,000 measured values
	LC-Display	size 90x64 mm
	Weight	approx. 250g
	Included in delivery	PC-Windows Software SmartGraph 3 for graphical and numerical representation of measured values / Instructions/ data cable/ battery/ WAGO connector / DIN rail bracket
	Interface	USB, LAN
	bus interface	RS 485
	Power supply	4 x LR6 AA Mignon, USB, (POE opt.)
	Max. operation temperature	-20...50°C
Input voltage 0-1V	Measurement range	0 ... 1V
	Accuracy	+/- 200uV +/- 0.1% of measured value
	Resolution	< 500uV
Current measurement	Measurement range	2-wires: 4 ... 20mA, 3-wires: 0 ... 20mA
	Accuracy	+/- 4uA +/- 0.1% of measured value
	Resolution	< 5uA
	Resistance	approx. 50 Ohm
Thermocouple K	Measurement range	-200°C ... 1200°C
	Accuracy	+/- 1°C +/- 0.5% of measured value at -200°C ... 0°C +/- 1°C +/- 0.2% of measured value at 0°C ... 1200°C
	Resolution	< 0.2°C

With up to 10 external channels/sensors per OPUS20E.

The OPUS20E offers the highest flexibility and is excellent value for money. It allows the connection of up to 4 external temperature and relative humidity sensors, as well as 2 further analogue sensors. Intelligent BUS sensors can be integrated via the OPUS20E's RS485 interface (e.g. particle counter).

Air flow and differential pressure sensors are typically connected to the OPUS20E via analogue inputs as opposed to the maximum of 4 external temperature or humidity sensors that can be integrated via a digital BUS protocol.

In connection with its LAN capabilities, the OPUS20E is able to realize universal measurement networks in real time. For standard applications the SmartGraph 3 comes into play, and in order to fulfil the 21 CFR 11 guidelines the well-established and proven MCPS7 software is available.



Kompatible Fühler für OPUS20E		Seite
Temperatur	PT100 Oberflächenfühler	17
	PT100 Einstechfühler	17
	PT100 Tauchfühler	16
	PT100 Lebensmittel-einstechfühler	16
	PT100 Tauchfühler	17
Temperatur/Feuchte	Digitaler TFF20	18

Sonstige kompatible Sensoren auf Anfrage.

Feuchte: Messumformer mit Display
 Strömung: Strömungstransmitter
 Differenzdruck: Diff.Drucktransmitter
 Partikel: Partikelzähler
 CO₂: CO₂Transmitter

With up to 10 external sensors connectable per OPUS20E

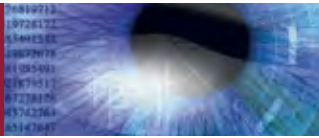

Lufft OPUS20E Configurations Examples

Network with up to 200 channels

The OPUS20E is equipped with an analogue input that allows the connection of 2 sensors with voltage and current output, or rather PT100 temperature sensors in 3 and 4 wire technology.

At the same time up to 4 Lufft temperature/humidity sensors can be connected to the datalogger via a serial input.

Each fully equipped OPUS20E is a 10 channel datalogger that can record various data. It also allows data to be retrieved online and offline.

Lufft OPUS20E for External Sensors			Order-No.
Technical data			
Thermocouple J	Measurement range	-200°C ... 1,200°C	
	Accuracy	+/- 1°C +/- 0.5% of measured value at -200°C ... 0°C +/- 1°C +/- 0.2% of measured value at 0°C ... 1,200°C	
	Resolution	< 0.2°C	
Thermocouple S	Measurement range	-50°C ... 1,700°C	
	Accuracy	+/- 1°C +/- 0.5% of measured value at -50°C ... 0°C +/- 1°C +/- 0.2% of measured value at 0°C ... 1,700°C	
	Resolution	< 0.2°C	
PT100	Measurement range	-200°C ... 500°C	
	Accuracy	+/- 0.2°C +/- 0.1% of measured value	
	Resolution	< 0.02°C	
Accessories	4 x LR6 AA Mignon		8120.SV1
	Power supply adapter		8120.NT
	Y Connector		8120.STY
	Cable	2m	8120.KAB2
	Cable	10m	8120.KAB10
(see page 12)	Temperature/ humidity sensor		8120.TFF
	Temperature/ humidity sensor (stainless steel sintered cap) for clean rooms		8120.TFFE

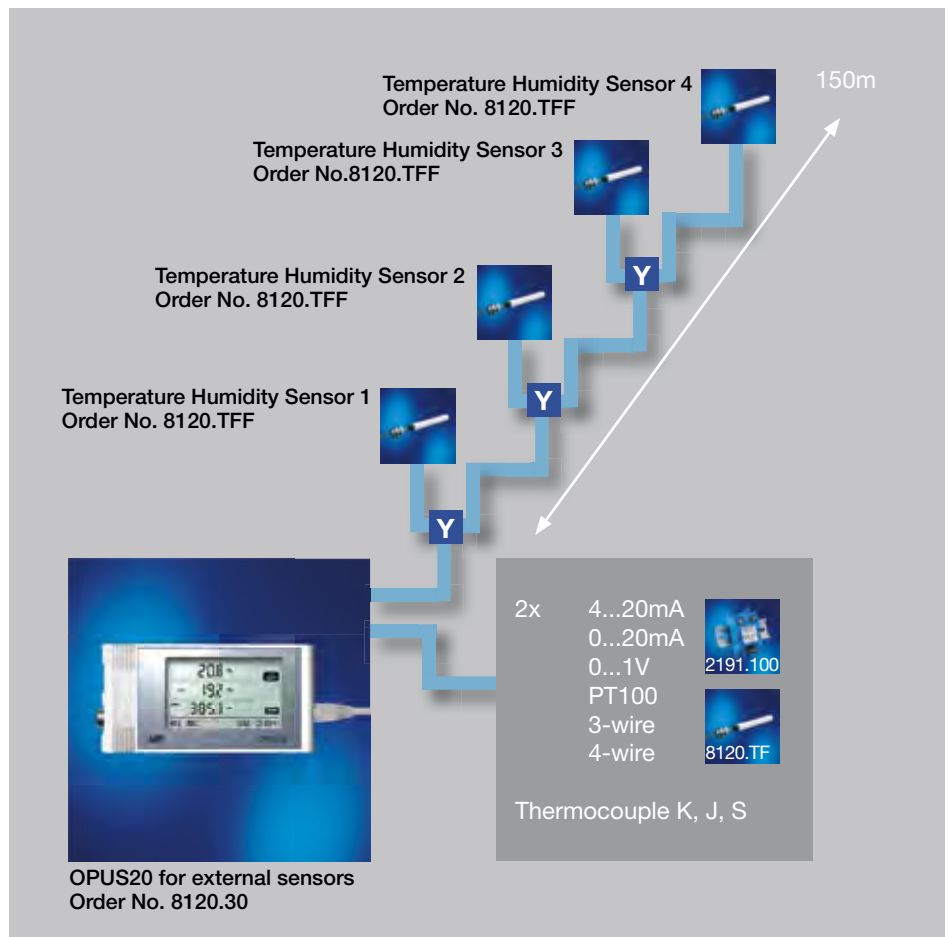

With up to 10 channels per datalogger transferring data in realtime.
Power supply via POE.

Comparison of SmartGraph3 / MCPS7 for Lufft OPUS 20-Series



Comparison of SmartGraph3 / MCPS7		SmartGraph3 (included in delivery)	MCPS7 (price on request)
Configuration	Scanning network	■	■
	Management of Opus devices in various projects		■
	Selection of sensors out of the sensor library	■	
	User-definable sensors	■	■
	Defining measurement and storage rates	■	■
Data storage	Configuration of alarm limits	■	■
	Storage of data during online measurements	■	■
	Linking of individual files, saving of partial measurements		■
	Automatic resumption of data recording after network failure or power cut		■
Data transfer	Importing of non-recorded measured values after network failure		■
	Direct connection via USB online/offline	■	
	LAN-TCP/IP online and memory readout	■	■
	Incorporation of further systems e.g. particle counter		■
Alarm	Data forwarding to e.g. control units or GLT		■
	Colour changes in display		■
	Alarm window (Pop-up)		■
	Log entry of events (audit trail)		■
	Alarm notification via SMS or e-mail		■
Exporting measured values	Alarm actions (e.g. to switch on/off relays...)		■
	Manual	■	■
User administration (21CFR11)	Automatic during an online measurement		■
	Access controlled by password		■
	Password history		■
	User groups		■
	Audit trail		■
Visualisation	Electronic record, electronic signature		■
	Screen layouts freely definable		■
	Y/T- diagramme		■
	Trend, bar, digital and numerical representation	■	■
	Calculation of statistical values (Min,Max,Med,Variance, Standard deviation)	■	■
	Client-server operation		■
	Process monitoring		■
Reporting	Web server		■
	Reports with own logos		■
	Reports in Excel pages		■
	Customer-specific evaluations over any number of time periods		■

When it comes to evaluation, have the works!
With the aid of powerful software, hand-held measuring devices are turning into archives.

Smart-Graph3

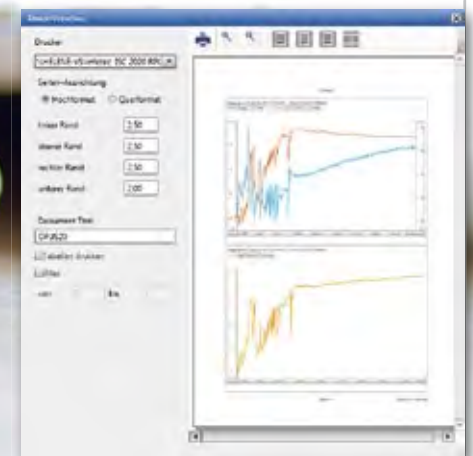
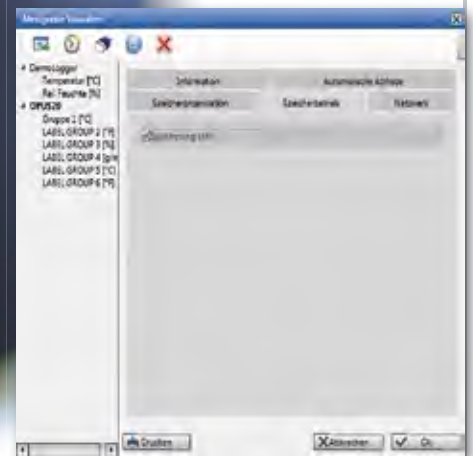

Software SmartGraph3 for Lufft Hand-held Devices and OPUS20-Series



Representation and Evaluation



SmartGraph3 for OPUS20-Series

- An OPUS20 datalogger is automatically recognised and added as a “network device”.
- In addition to its data-readout function, the software possesses a recording mode that enables parallel recording to be displayed on the computer.
- The data from any desired number of OPUS20 devices can be read out simultaneously.
- The zoom function allows for quick analysis of critical time periods.
- The exporting of measured data in csv format enables it to be imported into Excel.
- The device configuration can be printed out in order to check installation parameters.
- Alarm limits – like the measured data – are chronologically managed at various times so that when changes in alarm limits occur, they can be retraced.
- Automatic data readout of all measured data is supported.

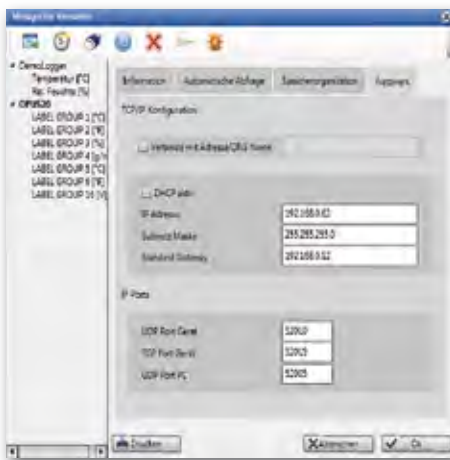

SmartGraph3 for Hand-held Measuring Devices

- A Lufft hand-held measuring device is automatically recognised and added by means of a USB interface.
- In addition to its data-readout function, the software possesses a recording mode that enables parallel recording to be displayed on the computer.
- The zoom function allows for quick analysis of critical time periods.
- The exporting of measured data in csv format enables it to be imported into Excel.
- Different measurement campaigns are archived in their respective accounts.
- All measurements recorded by the hand-held measuring device (also calculated values) are transferred to SmartGraph3.

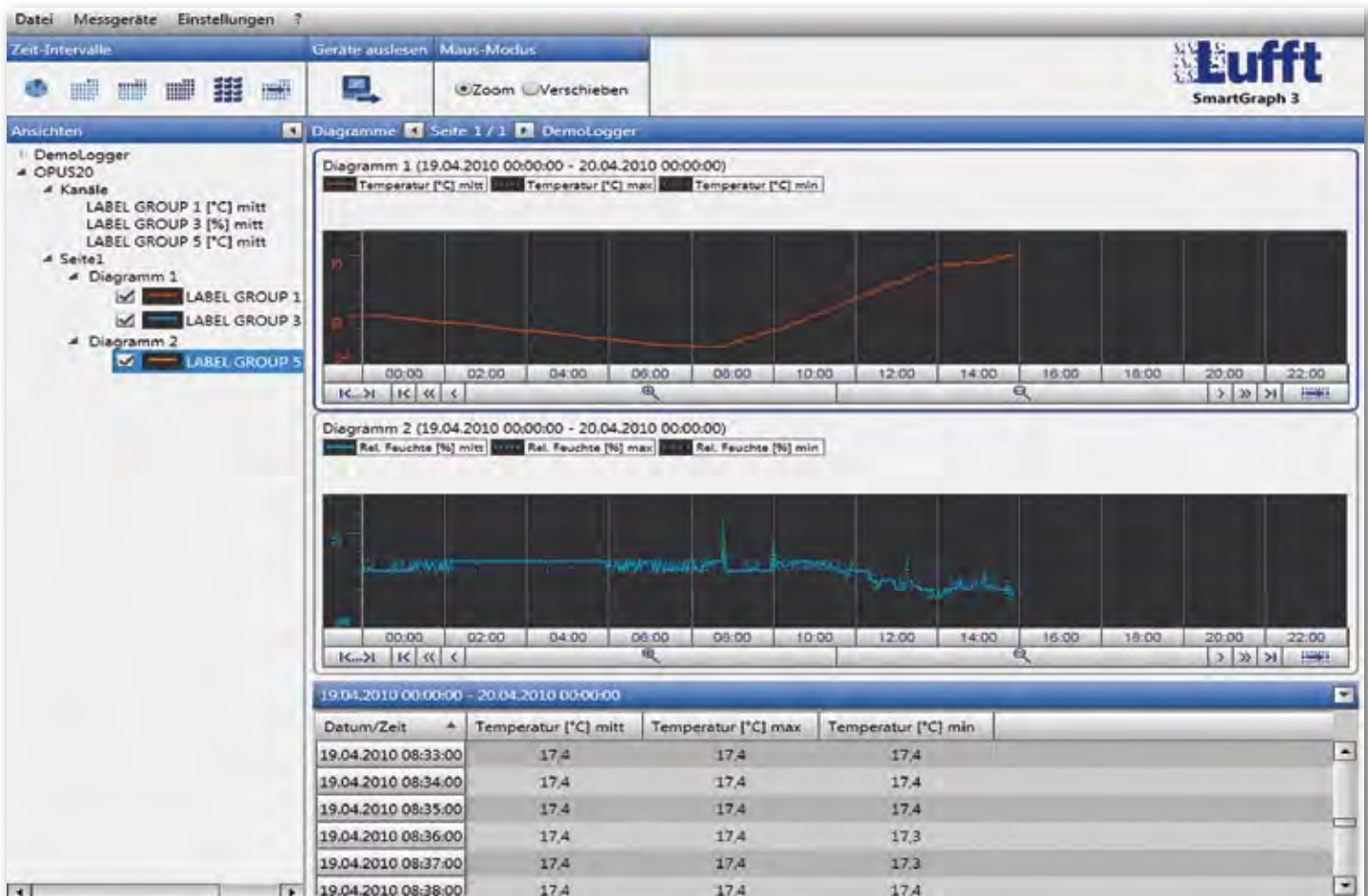



Software MCPS7 for Lufft OPUS20-Series

No place for coincidence. Anyone who records data in real time should not be satisfied with an “off the rack” solution only. Lufft has never done this and never will.

We have even put a lot of thought into the representation and evaluation of your measured data, and have developed special software that offers users numerous advantages and possibilities.

Data errors can be reduced to a minimum by means of clear processing and representation.

#	Gerät	Kanal	Einheit	Messtelle	Kommentar	Farbe	YMin	YMax	„ ²
1	OPUS20 - 1	Tc	°C		Temperatur		20	40	1
2	OPUS20 - 1	H_rel	%		rel. Luftfeuchte		0	100	0
3	OPUS20 - 1	H_abs	g/m ³		abs. Luftfeuchte		0	100	0
4	OPUS20 - 1	DPc	°C		Taupunkt		0	20	1
5	OPUS20 - 1	U-Bat	V		Batteriespannung		0	10	1

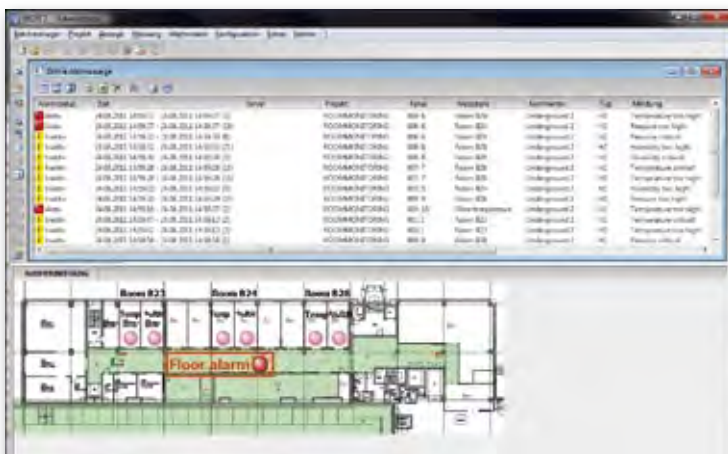
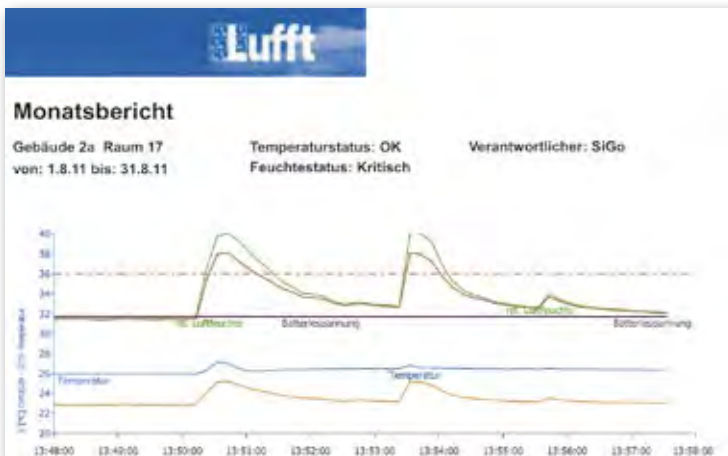

OPUS20

Aktiv

Geräte Nummer: 1

Schaltstelle: Ethernet: 192.168.5.16

Kanäle: Tc Tf H_rel H_abs DPc DPf U-Bat

Geräteinstellungen:
Abtastintervall: 10s Speicherintervall: 1m

Lokale Höhe [m]: Taster sperren

Software MCPS7 for Lufft OPUS20-Series

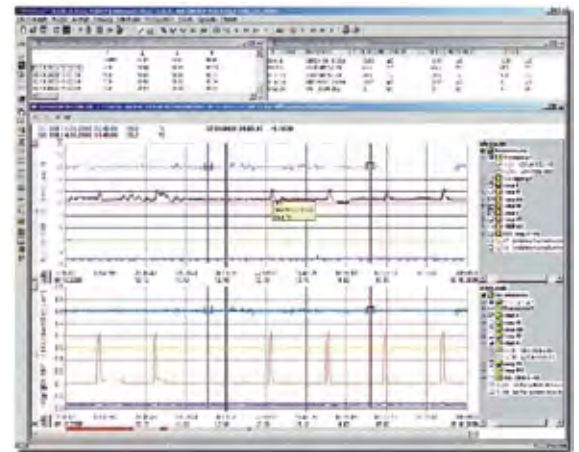
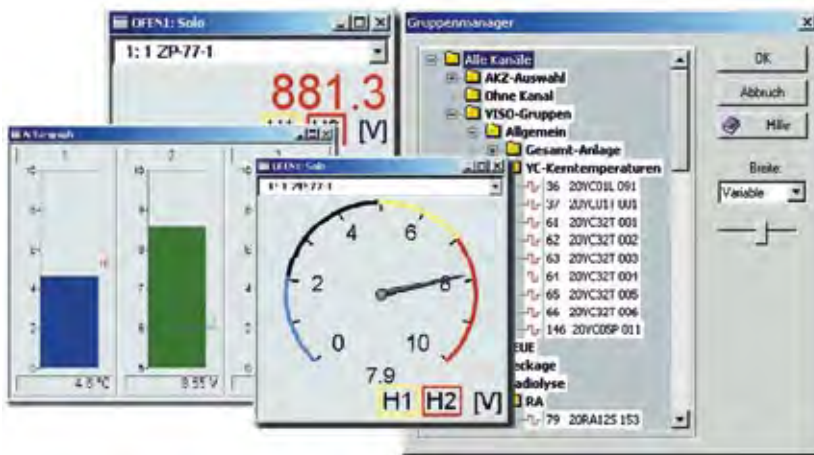

For Lufft the “User-Interface” is the icing on the cake, and for the user it’s the intuitive access to all functions.

Centralized Representation

Measurements are, to some extent, recorded every second: average values accumulate in the data logger, minimum and maximum values are observed, raw data is transferred to the central computer. Recording data in real time means that you have a large amount of data administration and at the same time have to arrange various measuring categories and points in a clear fashion. Some users are only interested in particular rooms, others want to have an overview of the particle sensors.

Consequently, a standard representation setup is simply insufficient. Instead of this, user-specific software is necessary such as MCPS7, which enables the

free configuration of graphic or numeric representation, or bar graphs; thus allowing you to incorporate and present comparable measuring categories in the same diagram.

In addition, MCPS7 has an integrated web server that visualises all the defined diagrams and places them in the intra-/extranet for other users. All you need is a password from the administrator.

Evaluation

The manual and automatic data export in the ASCII format offers the user additional advantages that exceed those of a standard display. There is also the possibility to define several formulae in MCPS7. In addition to this, daily, monthly and annual reports offer a simple overview of the

trends of the measured values. Furthermore, so-called MKT calculations supply special information – such as the median values of recorded temperature data (Mean Kinetic Temperature) – which is required in the pharmaceutical industry. Finally, in the audit trail of the MCPS7 package (21CFR compliant) all events are recorded: from system start and end, to user administration, changes to the device configuration, alarm messages plus confirmation text, the log-in and out of users, as well as sensor breakages and system crashes.

The software configuration of a sensor permits the flexible construction of a monitoring network design. The logger can incorporate many sensors; with configuration, the sensor is made acquainted with the flexible data acquisition module.

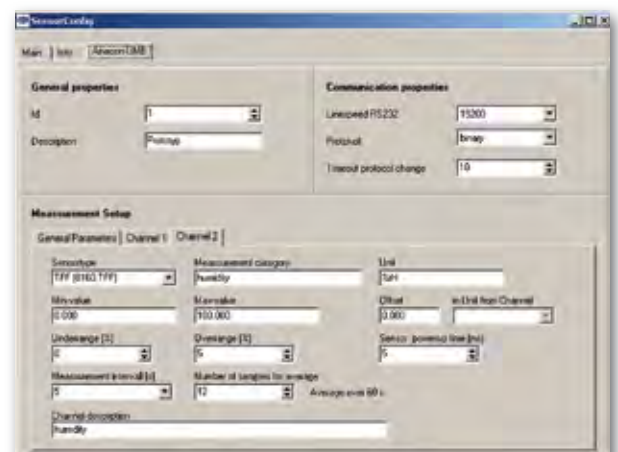

The specialists for every application.

Full variability for the recording of various measurement categories.

Lufft Receives Award:

Brand of the Century



Lufft named “Brand of the Century”

Lufft is awarded “Brand of the Century”

On Thursday evening, 22th November 2012 the pinnacle of German industrial brands were celebrated with word and image at the tenth “Brands of the Century” ceremony held at Berlin’s Hotel Adlon Kempinski. The standard reference work “German Standards – Brands of the Century” provides information on companies that help form the backbone of the “Made in Germany” brand. G. Lufft GmbH was named a “Brand of the Century” as part of the 10th anniversary edition of the brand lexicon. Book publisher Dr. Florian Langenscheidt was on hand to give the German Standards Brand Prize to Lufft CEO Klaus Hirzel who expressed his gratitude, especially for the recognition of 130 years of Lufft quality and innovations.

The history of Lufft began in 1881 as master optician Gotthilf Lufft founded a machine shop to build barometers according to a simple, but ingenious principle: measure barometric pressure with a metal membrane box that would expand and contract as the ambient pressure changed. Lufft’s barometers filled an existing gap in the market and by the turn of the century he had become the market leader in Germany. Over time, Lufft barometers became successful on an international level as well. Besides its climate measurement instruments for domestic use, Lufft was able to build its reputation for its service to industry, the craft trades and research. Lufft instruments were used on adventurous expeditions to Nanga Parbat in the Himalayas or in Greenland, for example.

Throughout its history, the family business had to face a variety of challenges, both to the business and in the production of new measuring devices. Today the Lufft brand stands for industrial climate measurement and professional environmental monitoring technology. Lufft now offers a broad and unique range of devices, data collectors and sensors for measuring physical variables. The Swabian company has sales around the world and subsidiaries in the U.S. and China. Currently a total of 80 employees work in development, production, sales and marketing departments at Lufft and embody the company’s principle of “Tradition and Innovation”, as they constantly seek to hone the precision of Lufft instruments. Production will start shortly of a new hand-held device, called the “world’s most accurate hand-held instrument for temperature measurement,” with an accuracy of +/- 0.00 “x”. The new series of hand-held devices will be on the market in 2013.



Thursday, 22th November 2012 – Prize award ceremony (from left) Dr. Florian Langenscheidt, Klaus Hirzel, Tobias Weil and Peter Englisch



Tradition and
Innovation:
A Passion for
Precision

Mechanical

Measuring Devices



Lufft Precision since 1881



*Display devices:
mechanical climate
measuring devices
with a very long
product lifecycle. No
wear-and-tear parts.
Complex calibration.
Everything under
control.*

Lufft's roots lie in climate measuring. The technologies have changed, but the company has remained the same. We have been specialists for temperature, relative humidity, air pressure and airflow measurements for over 100 years.

When it comes to mechanical measuring devices, Lufft has always stood for the superlative "the best" = "the most precise" with the longest life cycle. The transition from mechanical to electronic lies well in the past. In the meantime the electronic analogue technology no longer dominates, but rather "intelligent" sensors with the aid of built-in micro processors.

Today, there are still applications by which the quick, precise readout of "good" or rather "not good" is decisive. Whether in a museum, in the sauna or for "Indoor-Air-Quality" in industrial buildings, the measuring devices on this page seek to be the best mechanical display devices for professional demands. In this respect, the majority of these beautifully-crafted devices are in operation in laboratories and in industry. Nevertheless, there are also private customers who appreciate the durability and precision of our devices.

For these applications and users, we produce our mechanical measuring devices without making any compromises when it comes to quality.





Temperature / Humidity / Air Pressure Display Devices



Thermo-/Hygrometer Stainless steel			Order-No.
Technical Data	Dimensions	Scale 115mm Housing depth 33mm	5251.0561
	Design	Stainless steel housing	
	Weight	320g	
Relative Humidity	Principle	Durotherm	
	Measuring range	20...90% r.h.	
	Accuracy	±3% (30...90%) r.h., + 1 division of scale	
	Resolution	1% r.h.	
Temperature	Principle	Bimetal	
	Measuring range	0...50°C	
	Accuracy	±1°C (0...40°C), + 1 division of scale	
	Resolution	1°C	



Thermometer			Order-No.
Technical Data	Dimensions	Scale 115mm Housing depth 33mm	3251.0561
	Design	Stainless steel housing	
	Weight	300g	
Temperature	Principle	Bimetal	
	Measuring range	-22...55°C	
	Accuracy	±1°C, + 1 division of scale	
	Resolution	1°C	



Hygrometer			Order-No.
Technical Data	Dimensions	Scale 115mm Housing depth 33mm	4251.0561
	Design	Chrome-plated brass housing	
	Weight	110g	
Relative Humidity	Principle	Durotherm	
	Measuring range	0...100% r.h.	
	Accuracy	±3% (30...95%) r.h., + 1 division of scale	
	Resolution	1% r.h.	



Precision Barometer 870-1050 hPa Stationary and Portable			Order-No.
Technical Data	Dimensions	Scale 130mm Flange 160mm Housing depth 80mm	2187.70692
	Design	Chrome-plated brass housing and flange bracket	
	Weight	1,040g	
	Further measuring ranges	Available on request	
	Max. altitude	0...900m	
	Relative Humidity	Principle	
Measuring range		900...1,050hPa	
Accuracy		±1.5% of measuring range	
Resolution		0.5hPa	

Sauna Display Devices / Temperature / Humidity



Measurement

Thermo-/Hygrometer			Order-No.
Technical Data	Dimensions	Scale 125mm, Housing depth 35mm	5270.00
	Design	Plastic housing, anthracite	
	Weight	200g	
Relative Humidity	Principle	Durotherm	
	Measuring range	0 ... 75% r.h.	
	Accuracy	±3% (0...20%) r.h., + 1 division of scale	
Temperature	Resolution	2% r.h.	
	Principle	Bimetall	
	Measuring range	0 ... 120°C	
	Accuracy	±1°C, + 1 division of scale	
	Resolution	2°C	



Thermometer			Order-No.
Technical Data	Dimensions	Scale 125mm Housing depth 35mm	3260.00
	Design	Plastic housing	
	Weight	200g	
Temperature	Principle	Bimetal	
	Measuring range	-40...40°C	
	Accuracy	±1°C, + 1 division of scale	
	Resolution	1°C	



Thermometer			Order-No.
Technical Data	Dimensions	Scale 125mm Housing depth 35mm	3270.00
	Design	Plastic housing, anthracite	
	Weight	200g	
Temperature	Principle	Bimetal	
	Measuring range	0...120°C	
	Accuracy	±1.7% of measured value, + 1 division of scale	
	Resolution	1°C	



Hygrometer			Order-No.
Technical Data	Dimensions	Scale 125mm	4260.99
	Design	Plastic housing	
	Weight	250g	
Relative Humidity	Principle	Durotherm	
	Measuring range	0...100% r.h.	
	Accuracy	±3% (30...95%) r.h., + 1 division of scale	
	Resolution	1% r.h.	



Competent
Qualifi-
cation and
Calibration

Competent

Qualification and Calibration

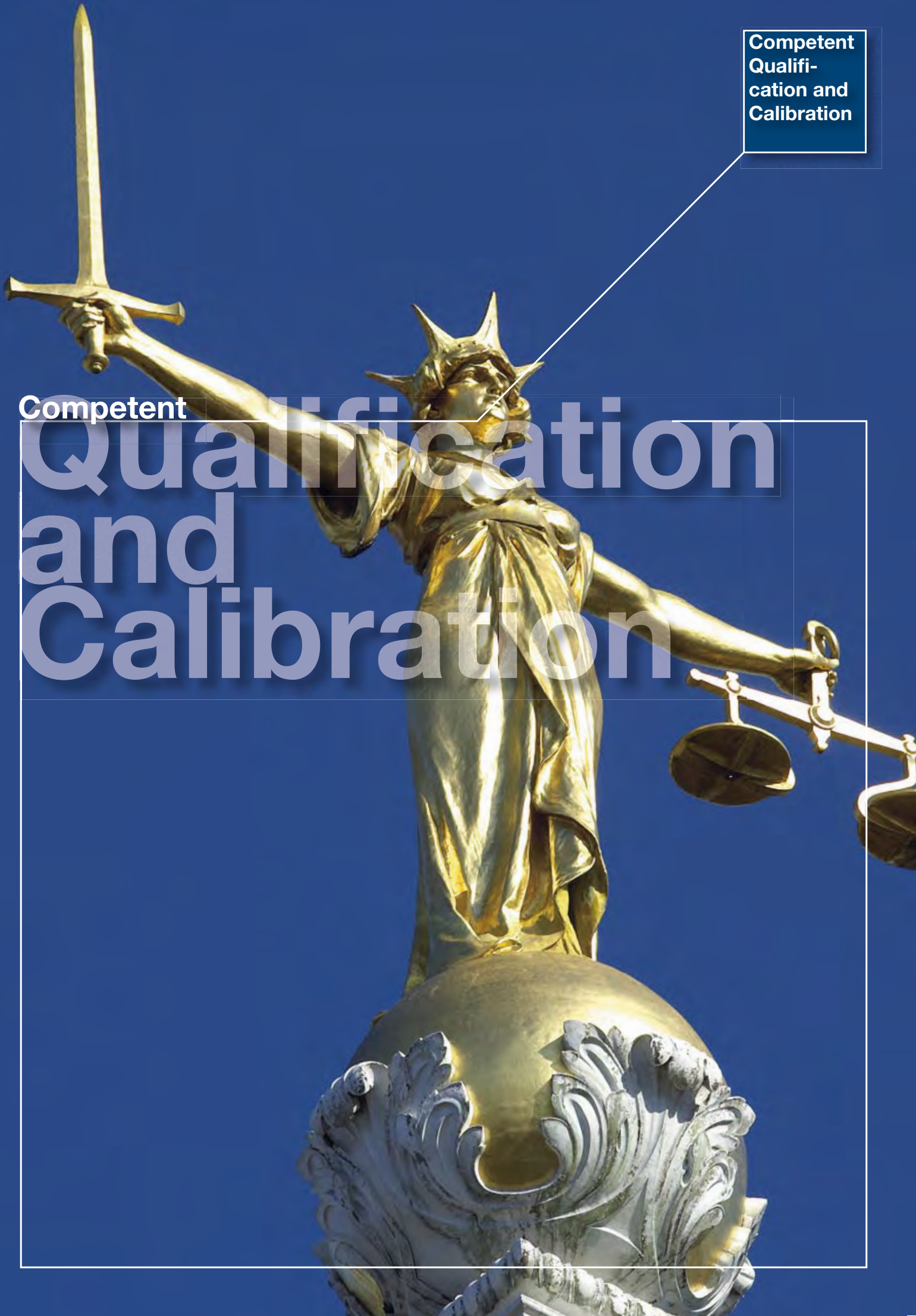



Qualification can only be done by qualified and experienced professionals. We ensure that you have excellent measuring technology experts at your side for such a task.

Imprecise measurements can have expensive repercussions. Therefore, Lufft products are tested according to the motto “To trust is good, to control is better”. Our products have to pass special tests that exceed that of conventional ones; firstly through a special type of qualification, both in production and at the customer, and secondly with the help of our DKD certified calibration, which ensures incorruptible results.

Qualification

A reliable monitoring system has to fulfil the highest requirements regarding preciseness and robustness. This is guaranteed by a test report that is provided by the manufacturer with each sensor. In addition to this, at Lufft the acquisition and analogue conversion of data is carried out in a special high resolution (16- or 32 bit technology), so that the preciseness of the sensors is retained.

A further quality feature is the local display that visualises measured values without losses due to rounding and with the same accuracy. At the same time identical measurement information is stored by central software in the archive. These quality requirements can be additionally tested during so-called “factory inspections” or audits of the customer’s production plant. Finally, there is an acceptance conducted in the plant and the highly sensitive goods are sent, sometimes travelling around half the globe.

A further “on-site qualification”, also known as the first calibration, is frequently conducted after the installation of the system. The requirements of “electronic records” (21 CFR 11) differentiates between the following types of qualification: Design Qualification (DQ), occurs during the requirement specification- and technical specification phase

- Installation Qualification (IQ), technical on-site acceptance such as an inspection of the wiring on the basis of the interface diagrams
- Operation Qualification (OQ), testing of the measurement chain from the sensor to the software, validation of the measurement chain, testing the accuracy of the sensor
- Performance Qualification (PQ), ensures the reliability during the products “life cycle”

Calibration

Imprecise measurements can have expensive economical repercussions, and for this reason a periodical adjustment of the sensors (justification), as well as a special comparison measurement (calibration) are of the utmost importance. During regular calibration a reference point measurements is compared with a reference standard, which normally has a much higher accuracy than the measurement under test. This round robin test is always a closed test, because these reference standards – whether directly or indirectly – have an accuracy that is based on and can be traced back to the official norm. In order to calibrate more than one

point, various conditions are generated on site according to customer requirements e.g. 3 different values for relative humidity. Such applications are indeed qualitative very sophisticated, and as such require specially trained personnel with profound experience in climatologic measurement technology; especially when dealing with the setup of comparison measurements regarding adjustment times.

The following applies to both qualification and calibration: there is a standard guideline, but no uniform procedure. Therefore, each user defines via the IQ/OQ his special requirements that have to be observed in both procedures respectively.

Incidentally, Lufft is also striving for the accreditation for an air flow measurement laboratory in the short-term future to add to its existing DKD laboratories for temperature, relative humidity and air pressure.

www.dkd-lab.info
www.dakks-lab.info

Experience in measurement technology since 1881
Lufft DAKKS-certified according to DIN EN ISO/IEC 17025

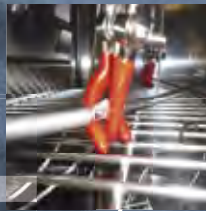

Free Management of Certificates Online

www.dakks-lab.de

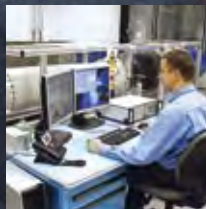
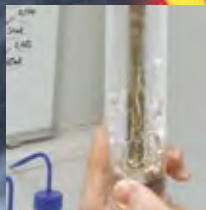

The triple point of water (balance of all 3 physical states solid, liquid and gas) is used to represent the International Temperature Scale and for the highest precision of temperature measurements in the milli-Kelvin range.

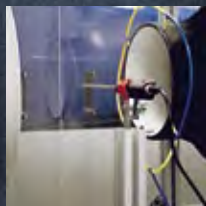

How reliable are your Measurements?

Even a state-of-the-art measuring instrument is still, strictly speaking, not one until it has obtained an internationally recognized calibration certificate. Only with its proven reliability can it meet its high demands. For this reason calibration technology, as well as production accuracy, has a deep-rooted tradition at Lufft. Since 1999 Lufft has been DKD-certified and DAkkS-certified since 2012.

Content of our Service:

- Creation of certificates with new deliveries
- Calibrated leasing devices for the period of calibration
- Controlling of test materials over the entire lifetime

Every sensor has to take a break once in a while. Each measuring unit fluctuates slightly during its operating time. This is not a question of a fault or a unit's functional efficiency, but a recognized phenomenon by all parties in this branch. A minimal fluctuation in precision occurs even with Lufft sensors; and our sensors are especially durable modules that are continually placed under extreme conditions (measuring CO₂ in incubators, humidity measurements in tropical conditions, e.g. at the equator).

Lufft, as a member of the Deutsche Kalibrierdienst (DKD), uses the prescribed reference norms from the Physikalisch-Technischen Bundesanstalt (PTB) for recalibration.

We offer an excellent service for each product:

Free comprehensive consultation that is tailor-made to suit your calibration needs, as well as free online management of certificates at www.dkd-lab.info / www.dakks-lab.info

E-mail to kalibrierung@lufft.de – and you can start managing your calibration certificates online straight away.



Absolute pressure

Calibration content:
700...1200 mbar
Pressure medium: air
(measurement uncertainty 0.15 mbar)



Temperature

Calibration content:
0.010°C at triple point of water (measurement uncertainty 5mK)
0.00°C at ice point (measurement uncertainty 10mK)
-40...+200°C in water bath (measurement uncertainty 15mK)
-40...+100°C in climate chamber (measurement uncertainty 100mK)

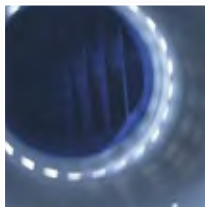

Airflow

Calibration content:
0.1...55m/s in wind tunnel
Airflow medium: air
(measurement uncertainty of 0.7% of measured value, at least 0.02m/s)

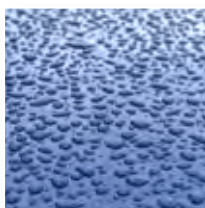

Relative humidity

Calibration content:
5...98% at 5...95°C (measurement uncertainty as of 0.2%)

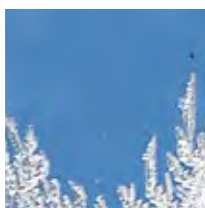

Dew point/ humidity generators

Calibration content:
-20...+95°C dew point temperature (measurement uncertainty of 80 mK)
5...98% at 5...95°C of humidity generator
(measurement uncertainty as of 0.2%)

www.dkd-lab.info
www.dakks-lab.info



Reference for Hand-Held Measuring Devices

MPA Stuttgart
Heel Baden-Baden
Tüv Arnstadt
Helmer Muhr am See
Matzner München
ESSKA.de Hamburg
ratio Tec Langenenslingen
Jahn Grub am Forst
AS-Wägetechnik Garching
T.A.S. Rostock
Stadtverwaltung Leonberg
Waller Eichstetten
HVF Weilheim
Weinbauinstitut Freiburg
Bosch Rexroth
VHB Holzbaubetriebe
Memmingen
GSG Geologie Würzburg
ESSKA.de Hamburg
ratio Tec Langenenslingen
Grünwälder Waagenteknik
Wuppertal
Honeywell Albstadt
Bauschutz Asperg
WSW Netz Wuppertal
Perfekter Halt Remscheid
MBE Menden
STRABAG Garching
Gebr.Hörner Schwäb.Gmünd
BS Beschichtung Greiz
Lau Hemer

Reference for OPUS20

Landratsamt Ravensburg
Veranstaltungs-u. Kongreß
Rosenheim
EADS Immenstaad
Phillips Böblingen
Hewlett Packard Böblingen
Festo Esslingen
Siemens Krefeld
BR Rigterink Bollberg
Femtosecond X-ray Hamburg
Long Life for Art Eichstetten
Siemens Krefeld
Diehlt BGT Defence Überlingen
Agilent Böblingen
Zumtobel Lighting Lemgo
Haupt Pharma Gronau
Universität Weimar
PTW Braunschweig
Eurocopter Donauwörth
Rehau Ingolstadt
PCI Augsburg
DLR Wesseling
ADC Lindau
Bosch Leonberg
Stadtbau Deggendorf
Biene&Natur Frensdorf
Airbus Hamburg
IFA Sankt Augustin
Trumpf Ditzingen
IBA Schwarzenbruck
Stadtarchiv WeilderStadt

a passion for precision · passion pour la précision · pasión

G. Lufft Mess-und
Regeltechnik GmbH

Address:
P.O. Box 4252
70719 Fellbach
Germany

Postal Address:
Gutenbergstrasse 20
70736 Fellbach
Germany

Tel: +49 711 51822-15
Fax: +49 711 51822-41

www.lufft.com
info@lufft.de



Subject to technical modifications · Lufft_Industry_05_2013

